

GFM Mini Shock Absorber

For use with gyro stabilized heads to reduce high & low frequency vibrations and hard impact shocks during high speed and rough crane moves. Connects to Mitchell or GF-8.

Weight :	9.8kg / 21lbs
Dimensions :	L38 x W19 x H34cm (14" x 7" x 13")
Maximum payload :	65kg / 143lbs
Lift range:	16cm / 6.5"
Temperature range:	-20° to +50° Celsius (-4 to +122° Fahrenheit)

Mounting the Mini Shock Absorber

Insert the Mitchell threaded shaft into the respective Mitchell Mount. Connect and turn the castle locking nut in a clockwise direction and finally lock it tightly by using the locking tool and lever.

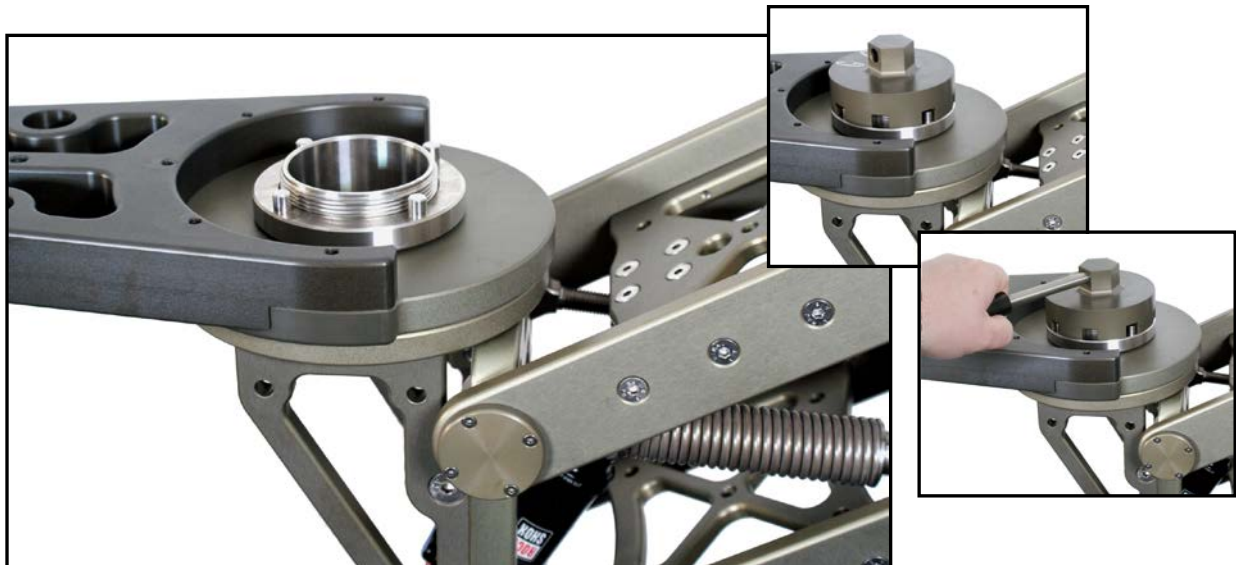

Mitchell or 150mm Bowl nose mount

The standard nose mount is Mitchell with an optional 150mm bowl mount. To exchange plates, remove the 6 bolts.



Mitchell nose mount



150mm Bowl nose mount

The are 4 standard assembly configurations



1. Rear underslung / front underslung



2. Rear underslung / front overslung



3. Rear overslung / front underslung



4. Rear overslung / front overslung

Adjusting to over / underslung

To adjust from under to over slung or viceversa, the 2 side locking bolts on each side of the bracket and the 2 inside locking bolts on the Mitchell plates must be removed. After removing the bolts the bracket can be repositioned and then securely bolted together.

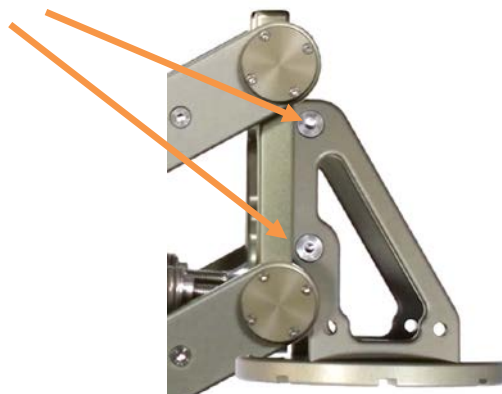
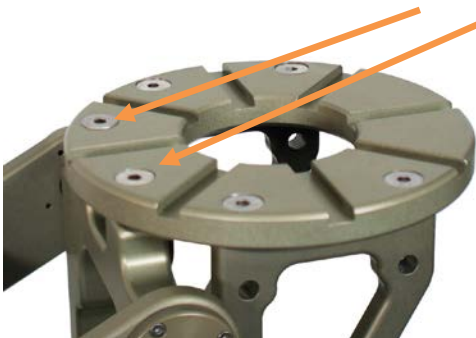

Setting the correct pressure

After mounting the Mini Shock Absorber and assembling the Iso Dampener, head and camera, the pressure of the suspension shock will need to be set.



To set the correct pressure, connect a high pressure pump to valve on the shock.

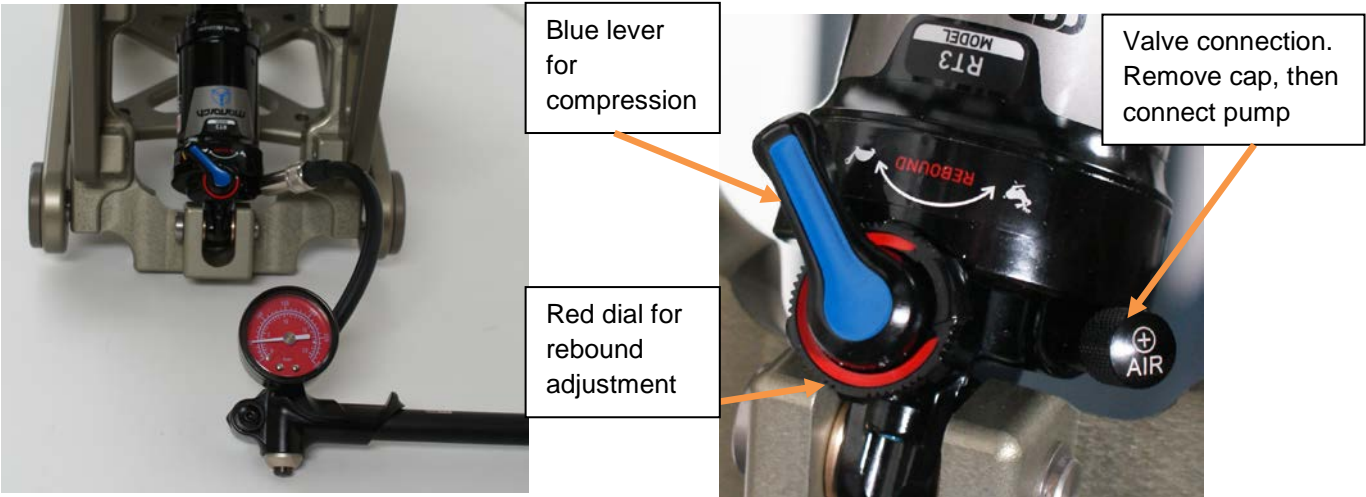

Depending on payload weight and surface conditions, setting the required air pressure and adjusting the compression and rebound will give the best results.

Setting the sag by altering air pressure (firmness of the spring).

Before you start changing the air pressure to adjust the sag, you will want to put the rebound damping dial (red) and the compression damping 'gate' lever (blue) on minimum. You do this by moving the red dial full anticlockwise (see photo).

You do these changes to let the shock move as freely as possible, so it can settle to give the most accurate sag measurement.

Tuning the Rebound Damping

The red dial controls the speed that the suspension extends back to normal after hitting a bump. Rebound damping reduces the pogo effect of the suspension bouncing back too quickly after compressing from a bump.

The Compression Damping 'Gate'

The blue lever controls the slow compression damping or the 'gate'. The minimum setting opens the compression damping gate and sets the suspension compression at its most soft which is best for rough terrain.

The recommended position of both knobs is to the maximum anti clockwise, so that valves are always open

Approximate pressure level to different payloads. It is recommended but not obligatory.

Payload kg / lbs	40kg/ 88lbs	45kg/ 99lbs	50kg/ 110lbs	55kg/ 121lbs	60kg/ 132lbs	65kg/ 143lbs
Pressure psi / Bar	11psi/ 0.75Bar	12,56psi/ 0.86Bar	13,95psi 0.96Bar	15,35psi 1.05Bar	16,74psi 1.15Bar	18,14psi 1.25Bar

For finer tuning and additional tension support, adjust the 2 springs so that they are tensioned. Both springs must be adjusted to the same degree of tension. Viewed from the rear of the Mini Shock Absorber, turning the springs clockwise will increase the tension.

